

FACTOR

Table heights: 740 mm, 900 mm, and 1050 mm.

Corners sharp or with a radius, allowing for more customization.

Accessories like matching lids and cable management trays are available.

Tabletops: rectangular, square, and round, available in sizes up to 7200 × 3000 mm, 3000 × 3000 mm, and Ø3000 mm, respectively.

Available with straight and chamfered edges and big variety of decors: veneer, stained veneer, wood grain laminates, plain laminates, nano laminates, and linoleums.

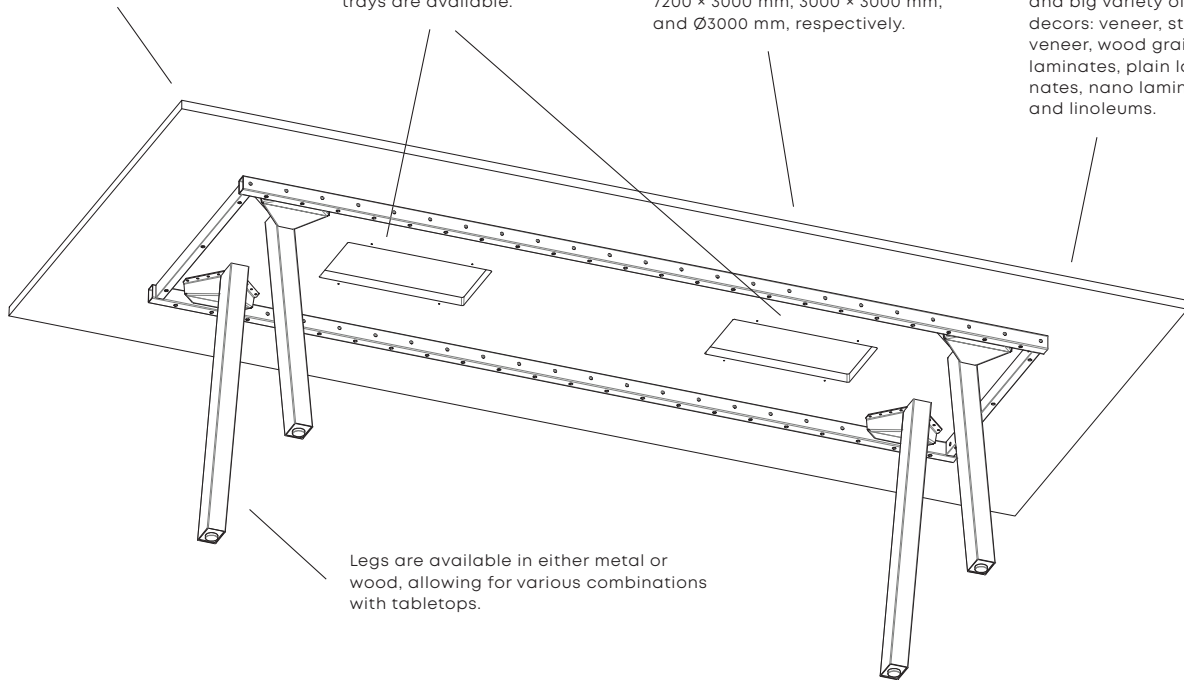

Legs are available in either metal or wood, allowing for various combinations with tabletops.

Factor is a versatile table that seamlessly blends style, functionality, and sustainability. Its large-size options, customizable aesthetics, and flexible configurations make it ideal for various layouts from meeting rooms to communal spaces.

Available as a conference table, as well as in counter and bar-height options, Factor is designed to meet the needs of dynamic communal areas. Whether for collaborative spaces, stand-up meetings, or casual dining, Factor offers the perfect solution. Factor is a modern choice for spaces where connection, collaboration, and creativity thrive.

TESTING AND WARRANTY

- Factor is designed for severe contract use.
- The table passed testing according to the required EN standards.
- Factor carries the HOWE 5-year warranty.

