

# TEMPEST® FLIP-TOP

Ease of handling and operation is a key benefit of Tempest flip top tables, as there is no lifting involved

Retractable linking and levelling brackets for multi-directional linking

The flip-top mechanism allows flipping the tabletop from horizontal to vertical for nesting and storage

Hinges connected to the beam provide easy noiseless flipping of the tabletop

Various cable management solutions available

Versatile top shapes and sizes available

Matching ABS or hardwood edge

Concealed castors (within the base foot) permit easy 'wheel-barrowing' of tables around the space

Frame in chrome3 (the most environmental friendly chrome solution) or powder coated finish

The 'T' leg permits maximum seating capacity around the entire perimeter of the top; nobody gets a leg!

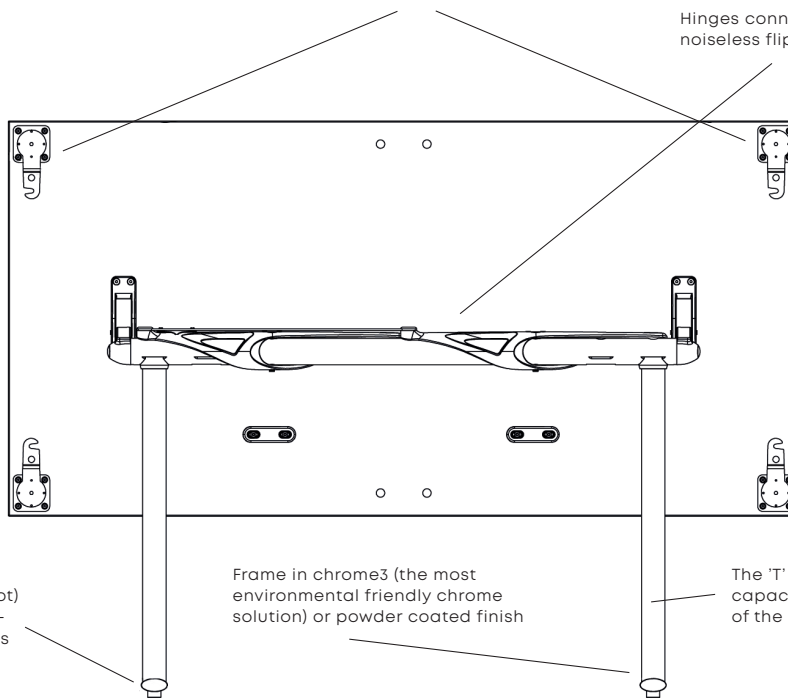

The Tempest table is considered the world's leading flip-top table system in terms of its unique space-saving and manageability qualities. Tempest is often referred to as the "zero weight" table system by combining a flip-top mechanism and integrated castors allowing the table to be moved around easily. When not in use, the tables can be nested to optimise space.

Tempest's beautiful and rock solid flip-top mechanism by KOMPLOTT Design is an incredible attribute both in terms of design and functionality. The multi-directional linking system allows the users to link the Tempest table in any direction they may please. Finally, Tempest also offers a modesty panel system and solutions for power and data.

## TESTING AND WARRANTY

- Tempest is designed for severe contract use.
- The table passed testing according to the required EN and BIFMA standards.
- Tempest carries the HOWE 10 year warranty.

