

40/4

A moving legacy



40/4 by David Rowland / An icon moving the world

HOWE
MOVING DESIGN
SINCE 1928

Moving

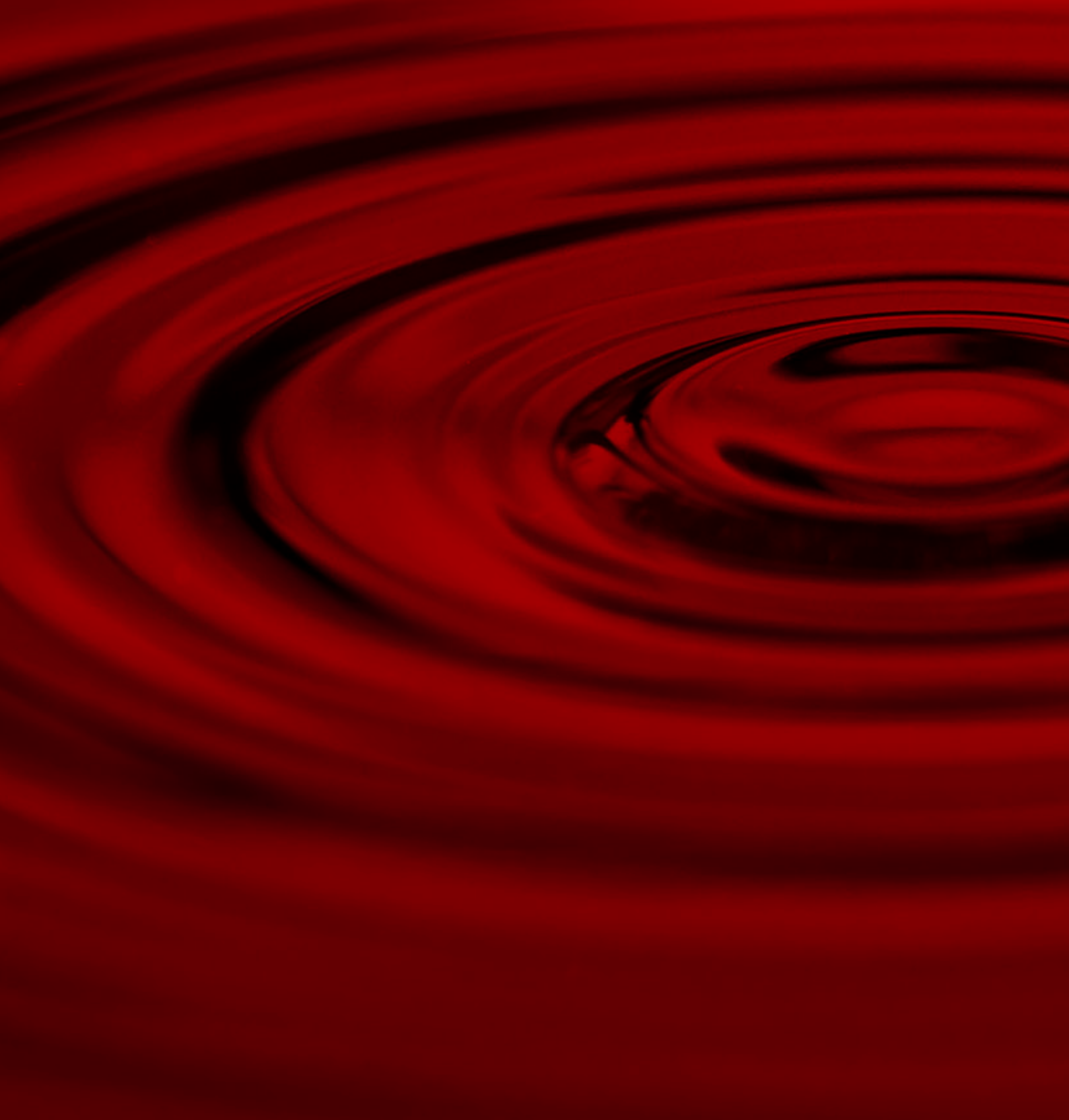

design

We believe in the sense of movement at HOWE; the idea that what we do is not only moving the levels of craftsmanship or the confinements within design but also the people who use it every day.

This is why all chairs and tables from HOWE offer impeccable functionality. You can fold them. You can stack them. You can roll them any way that you want, optimising the spaces in which we work, think, study and communicate.

Just as you can feel comfort in them; the look, the originality, the way form follows function to the very last detail. Time and time again.

We are HOWE and we believe in moving design. Since 1928.



Designer
David Rowland

Intelligent, purposeful, refined design

The journey of the 40/4 chair began one afternoon in Rowland's New York apartment when he was experimenting with stackable chair designs and challenged himself to figure out a design that would allow the greatest number of chairs to fit into the smallest space. Eventually, he realised he could stack 40 chairs to a height of 4 feet. Rowland continued to develop the 40/4 in his spare time for the next eight years, constantly refining the design. He built 32 handmade full scale models in order to perfect the principles, form, and comfort of the chair.

40/4 chair
by David Rowland
1964

David Rowland



Designer
David Rowland





40/4
David Rowland





Recognised as the world's first stacking chair

The 40/4 chair is recognised as one of the most important and groundbreaking designs of the 20th century for its compact stackability, excellent ergonomics and comfort, versatility, and timeless grace.



Learn more: <https://davidrowland.design>

40/4

Moving the world

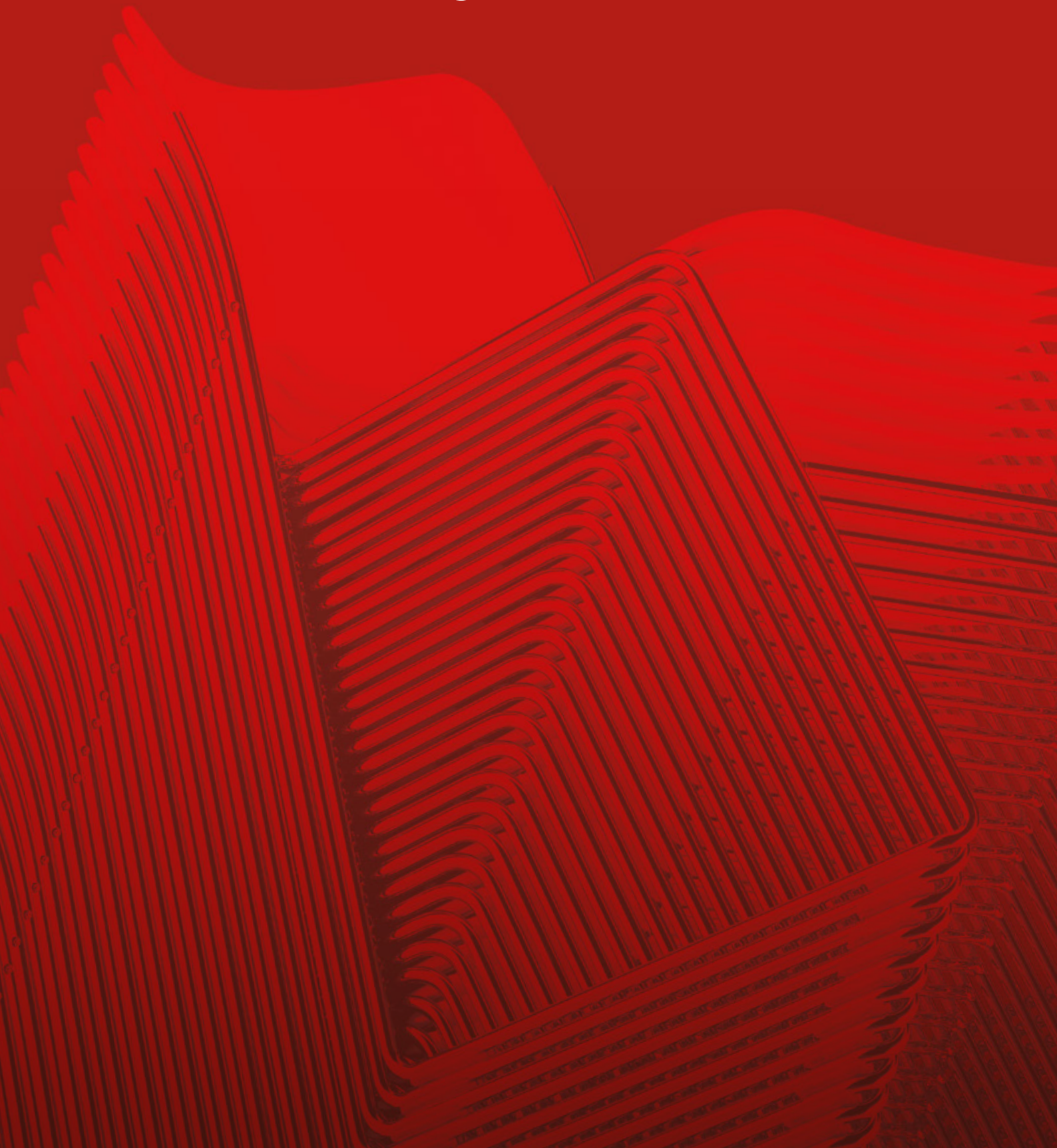

Most people see the 40/4
as a pioneering design that
has stood the test of time.

We like to think of it as
a legacy that continues
to move you in new ways.

40/4

David Rowland







40/4 upholstered side chairs
KULTURØEN
Middelfart, Denmark



SIMPLY REMARKABLE

David Rowland's 40/4 stackable chair is one of the most important designs of the 20th century.

Its elegant lines, excellent ergonomics, and unsurpassed ability to create space without taking up space continues to attract architects and designers. An indisputable icon of multifunctional design, the 40/4 chair is featured in design collections and museums all over the world.

Long-lasting durability

Our hard-wearing furniture solutions have a proven track record stretching back more than 45 years - they simply become companions.

2500 40/4 chairs by David Rowland at St. Paul's Cathedral in the UK have been used and moved each day since 1973 and are still in good condition.





40/4 veneer side chairs
ST. PAUL'S CATHEDRAL
London, UK



40/4
David Rowland





40/4
David Rowland



40/4 veneer side chairs
MOGENS DAHL
- INSTITUT FOR MUSIK
Copenhagen, Denmark



Optimising space

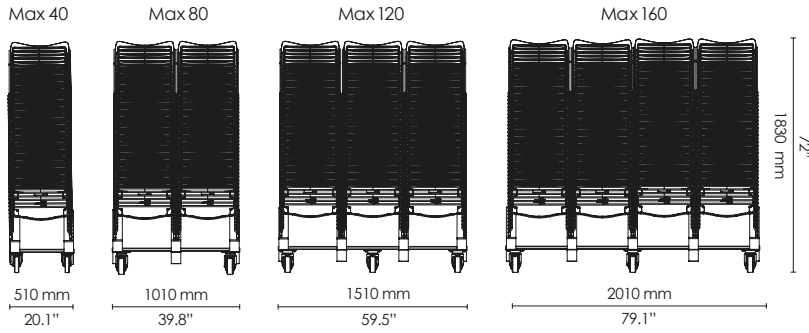

40 chairs on a single dolly take up only 0,47 m² / 5.1 ft² of floor space.

160 chairs on a quadruple dolly take up less than 2 m² / 21.5 ft² of floor space.





40/4 veneer side chairs
CANTERBURY CATHEDRAL
Canterbury, UK

”

The service of design
to the world is to
be purposeful and
problem-solving.

David Rowland



Designer
David Rowland



40/4 is as strong and sturdy as it is refined. Its gentle, contoured lines disguise the chair's rugged durability. The elegant and minimalist design allows it to effortlessly exist within diverse architectural venues.

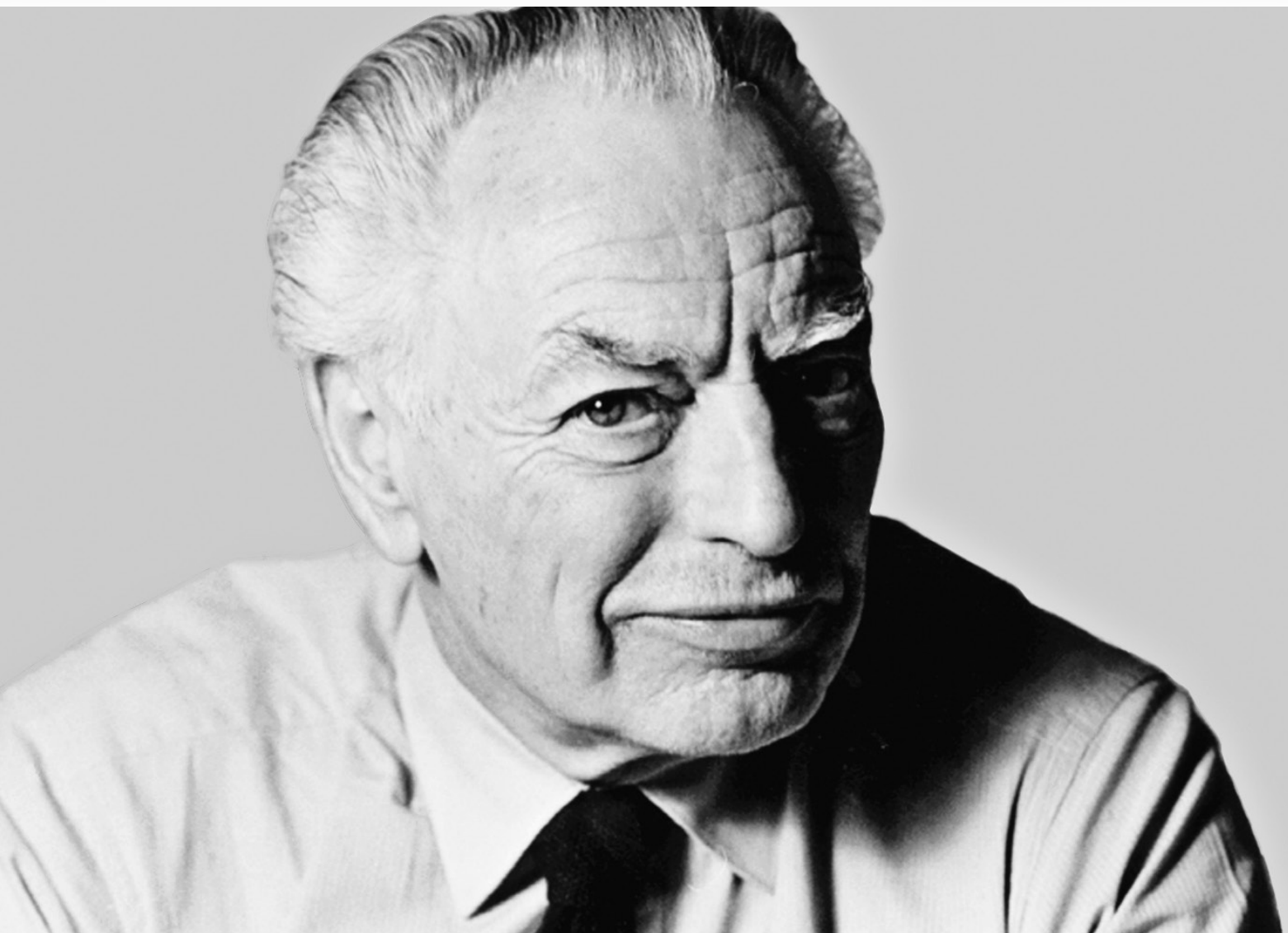



40/4
David Rowland





40/4 side chairs
PFARRZENTRUM
Hard, Austria

Photo: Marcel Mayer
Architect: Architeccthaus Früh

40/4 side chair

Veneer / plastic / metal / upholstered / outdoor

Veneer / plastic

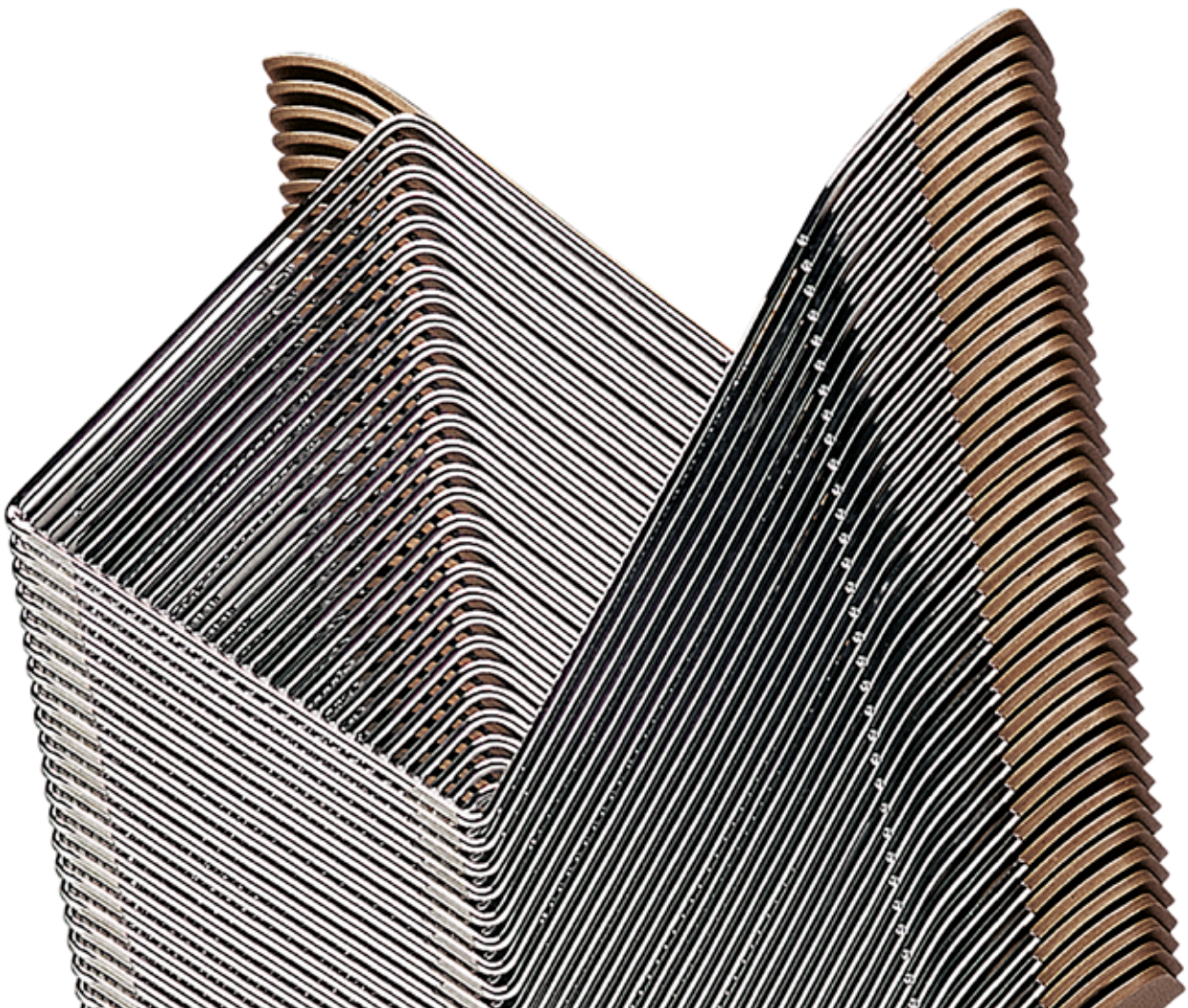
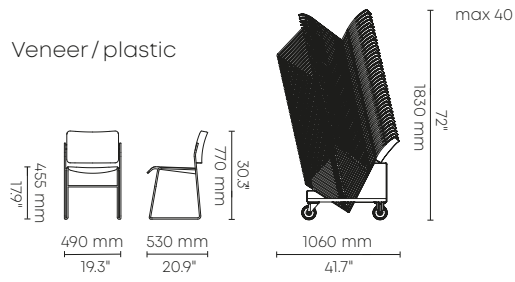



40/4 veneer side chairs + Tempest tables
KASARMIKATU 21 - PIHKA KASARMI
LUNCH RESTAURANT
Helsinki, Finland



40/4
David Rowland





40/4 veneer side chairs
with custom engraved monogram
CHAPELLE DES JÉSUITES
Saint-Omer, France

Custom engraved monogram





40/4
David Rowland







40/4
David Rowland

40/4 armchair

Veneer / plastic / upholstered / outdoor

Upholstered

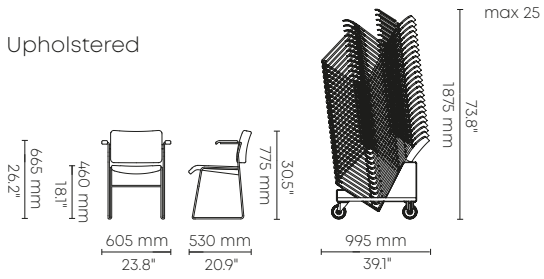







40/4 upholstered armchairs
UN CITY
Copenhagen, Denmark



40/4
David Rowland



40/4 upholstered armchairs
KAVA ANTWERPEN
Antwerpen, Belgium





40/4 linking

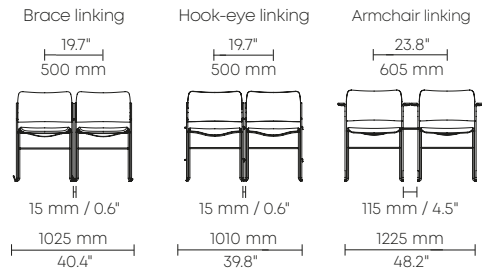

Brace linking



LD5S linking (EN 14703 compliant)

Armchair linking

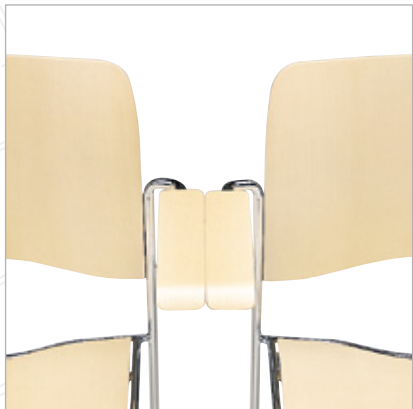

Hook-eye linking



Fin linking



40/4
David Rowland



40/4 upholstered armchairs
DANISH CORPORATE REFERENCE
Nordborg, Denmark



40/4 writing tablet

With or without cup holder
Right or left-handed version

Side chair

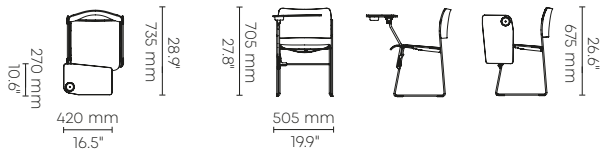

Armchair

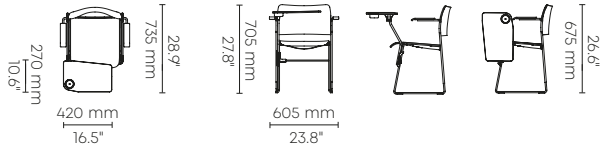





40/4
David Rowland

40/4 swivel

Veneer / plastic / upholstered

Side chair - veneer / plastic

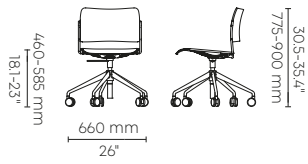

Armchair - veneer / plastic

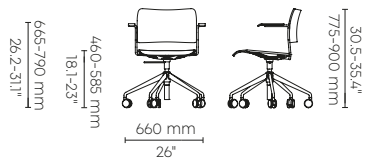



40/4 swivel armchairs
+ Simpla tables
TREFOR
Kolding, Denmark





40/4
David Rowland





40/4 auditorium

Veneer / plastic / upholstered

40/4 upholstered auditorium chairs
with writing tablets

UCC CAMPUS CARLSBERG
Copenhagen, Denmark

Photo: Paustian



40/4
David Rowland

40/4 xtra

Veneer / upholstered

Veneer

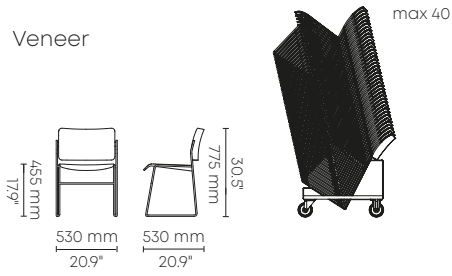

XTRA TO LOVE

40/4 xtra is a slightly larger version of the original 40/4 chair. The seating is wider, the back is higher, yet the impeccable comfort of this classic is uncompromised.



40/4 xtra



40/4 standard size chair





40/4 lounge

Veneer / upholstered

Veneer

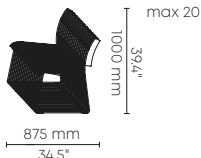
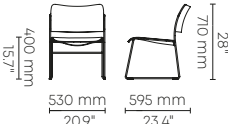



40/4
David Rowland

40/4 barstool

Veneer / plastic / upholstered / outdoor

Veneer / plastic

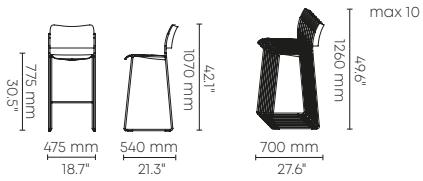

Counter height
Veneer / plastic

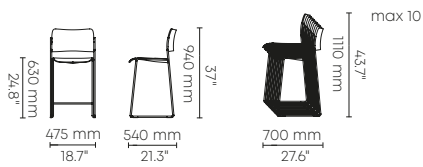

40/4
David Rowland



40/4 upholstered barstools
DANISH CORPORATE REFERENCE
Nordborg, Denmark

40/4 wood frame

Veneer / seat upholstered

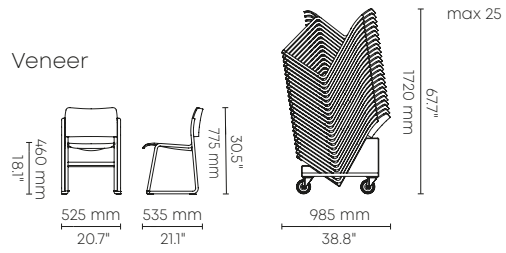

Floor linking







40/4 upholstered side chairs + Tutor tables
ESSEC BUSINESS SCHOOL
Cergy-Pontoise, France





Photo: © Anton Grassl / Esto

40/4 veneer side chairs
SILVER SPRING CIVIC CENTER
Silver Spring, USA



^ 40/4 plastic side chairs
THE SIBYL CENTRE AT THE WOMEN'S COLLEGE,
UNIVERSITY OF SYDNEY
Sydney, Australia

40/4 veneer side chairs v
ESCUELAS PÍAS
Madrid, Spain



40/4
David Rowland



Photo: Carlos Chavarria

Photo: Fris & Moltke

^ 40/4 beam seating
ECODROOM
Geel, Belgium

40/4 semi-upholstered side chairs v
IKAST GYMNASIUM
Ikast, Denmark



40/4 veneer side chairs
AIRBNB INC.
San Francisco, USA

Moving Sustainability

At HOWE we believe that good design is design that moves you. Just as we believe that every good design must contribute to a more sustainable future.

Because our world needs it more than ever.

No matter the scale or requirements of your project, no matter how you want to work out your ideas, we continue to provide you with the utmost sustainable value.

We use the environmental-friendly chrome III, not the conventional chrome IV. We do not use any kind of toxic chemicals and have plastic identification codes for maximum recycling value. In fact, we have a complete environmental guide and certifications, ISO 9001, ISO 14001, FSC and PEFC, also Global GreenTag^{Cert™} and HPDs to back it up.

This is our move. This is us, ensuring that every design from HOWE delivers a valuable difference, whether it concerns originality, functionality or indispensable sustainability.

Because it has never made more sense.



Promoting Sustainable Forest Management
www.pefc.org



Moving Sustainability



The mark of
responsible forestry



Suffolk One case story

Suffolk One provides top level education facilities for over 2,000 16 to 19 year old students. The objective was to develop an inclusive and inspirational Learning Centre, sitting in the heart of a collaborative learning community where all talents and achievements are valued. The innovative design acts as a mirror for the fresh approach to education.



40/4 chairs + Tempest tables
SUFFOLK ONE
Ipswich, UK

40/4

BY DAVID ROWLAND

When choosing seating, sturdiness of the chairs was important. In a school environment, the chairs are likely to experience hard and frequent use. Suffolk One chose the 40/4 chair due to its durability, as well as its simple and elegant design.







Monash University case story

Monash University has pioneered a new educational environment of 65 learning spaces – both formal and informal – for its 25,000 students. In doing so, it has created a concept called ‘education innovation’, which inspires a more contemporary approach to learning. Here the focus is placed as squarely on pre- and post-class learning as on traditional in-class learning.



40/4 chairs + SixE chairs
MONASH UNIVERSITY
Melbourne, Australia

Photo: Jesse Hisco Photography





STUDY SPACES AND NOOKS

The architects have designed in a vast number of informal study spaces and nooks. For many of these spaces, they've chosen HOWE as a design partner to provide seating. Two of HOWE's chair families – 40/4 and SixE – sit within the Clayton Campus, across meeting rooms and informal breakout spaces, canteen facilities and study areas.



”

The pre- and post-class learning is self-directed and ideally happens on the university campus, with students learning from each other. It's a learning process that needs an informal setting.

Meaghan Dwyer
Principal at
John Wardle Architects

Sacred space

Salisbury Cathedral in the UK is a beautiful, historic building and a world-class heritage attraction. As the Cathedral is host to many different events, chairs often need to be moved, removed, and stacked. The design of the furniture, however, must respect the dignified environment of the cathedral. The 40/4 chair was chosen for its proven durability and simple design.

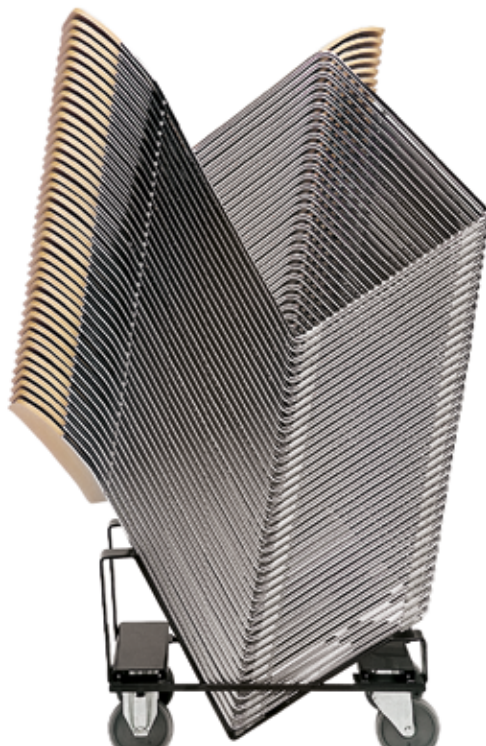



40 ///4